



# IQ™ Central Control System

## The Irrigation Management Solution for Smaller Sites

The Rain Bird IQ Central Control System provides cost-effective, multiple-site centralized irrigation control from a single computer. IQ empowers the Landscape Maintenance Contractor, Property Manager, or Irrigation Water Manager to monitor and control irrigation at multiple remote sites. IQ communication capabilities virtually eliminate the need to travel to remote sites to make programming changes or adjustments. Manual operation and programming functions that were performed only at the site irrigation controller can now be done from the IQ central computer.

### Applications

The IQ Central Control System can be utilized for a variety of applications, ranging from residential to commercial. Modular components allow the system to grow with your needs, eliminating the installation of multiple enclosures and extra external wiring connections.

### IQ Software

Insert the IQ CD and it starts automatically installing IQ Central Control on your computer. A Quick Start guide walks you through the simple steps to activate and set up your software.

IQ software incorporates an easy-to-navigate graphical user interface with water saving features like ET, Seasonal Adjust, and Cycle+Soak™. Buttons for common tasks are located on the home screen.

### Communication

Multiple communication options allow wired or wireless connections between the IQ central computer and its satellite controllers. IQ software uses your computer's phone modem or communication port to synchronize computer-generated programs with your satellite controllers. Logs are also retrieved during synchronization to report system activity and status.

### Central Software Features

- User-defined sites (groups of satellite controllers with common adjustments)
- All ESP-LX Modular stand-alone controller features
- Group site adjustments (auto/off, seasonal adjust% or ET)
- Program review with projected start and end time calculations
- Dry-Run utility graphically displays program operation including flow, time, and warnings for water window and maximum flow violations
- View site logs and alarms on screen or in printed reports

### Water Management Features

- Station run times in seconds, minutes, and hours
- Cycle+Soak™ by station
- Program adjust % by program
- Daily seasonal adjust %
- Monthly seasonal adjust % automatically adjusts station runtimes for each month
- Daily ET adjustments
- Monthly ET adjustments —automatically adjusts station run time for each month
- Programmable rain delay and calendar day off
- Programmable delay between stations by program

### Manual Operation Features

- Real-time satellite activity status
- Manual station start, program start, advance, and cancel
- Variable test program
- RASTER™ (RApid Station TEst Routine) provides station output test to detect and diagnose field wiring or solenoid problems
- Auto/off dial and sensor active/bypass switch settings can be overridden from the central
- The ESP-LX Modular Controller and DTC-LXM Communication Interface Cartridge firmware can be re-flashed from the computer



### Software Capacity

25 Sites (user defined groups of satellites) and 250 total Satellite Controllers

### GSP Features

- Software purchase includes 6-month Global Support Plan
- Extended Global Support Plans available
- Toll-Free phone support
- Emergency DTC-LXM Communication Interface Cartridge replacement

### Minimum Computer Requirements

- Windows® XP-Professional SP2
- Pentium IV 1.8 GHz
- 512MB RAM
- 200 MB free hard drive space
- 1024x768 screen resolution
- CD-ROM
- Communication modem/port
- Computer not included with software package

### How to Specify/Order

**IQ-STD-CD**

IQ Software Package



## LXM-DTC Satellite Controller

The Rain Bird ESP-LX Modular Controller is the field controller for the IQ Central Control System. This feature-rich control device comes standard with 8 stations, and is expandable to 32 stations, using 4- or 8-station snap-in modules. Control modules are hot swappable, utilizing plug-and-play technology.

A cost-effective DTC (Direct-to-Central Communication Cartridge) can be added to the ESP-LX Modular Controller, upgrading it to a LXM-DTC Satellite Controller. Programs created using the IQ software can be synchronized with the satellite controllers via wired or wireless communication links. Once downloaded, these programs can be viewed and modified locally at the satellite controller. Events logged at the satellite are automatically retrieved during synchronization and can be viewed in the IQ software event log.

Turn the LXM-DTC Satellite Controller dial to the IQ Communications position to view DTC configuration and communication information in the controller display. Indicator lights on the DTC cartridge also show current communication status.

A sensor input connection at the LXM-DTC Satellite Controller integrates external weather or high flow shut-off sensors enabling automatic shutdown of selected irrigation stations. Changes in sensor status are automatically reported to the IQ central computer during the next satellite synchronization.

LXM-DTC Satellite Controller auto/off dial and sensor active/bypass switch positions can be remotely overridden from the IQ central computer. This feature eliminates trips out to the site to change a switch position that has accidentally been left off.

## Satellite Controller Features

- ESP Extra Simple Programming
- Large LCD display
- Plastic, locking, wall-mount enclosure
- Indoor and outdoor models with internal transformers
- Modular station capacity: 8 to 32 stations in 4 station increments
- Hot swappable modules with LED status light
- DTC Communication Interface Cartridge with internal phone modem and/or RS-232 connector for external modem

## Water Management Features

- Station run time in seconds, minutes and hours
- Seasonal adjust % by program
- Monthly season adjust % automatically adjusts station runtimes for each month of the year
- Cycle+Soak™ by station
- Sensor input programmable by station with bypass switch
- Programmable Rain Delay
- Programmable Calendar Day Off
- Programmable delay between stations by program

## Additional Features

- Program and total station run time review
- Master valve/pump start circuit programmable by station
- Manual station start, program start, and variable test program start with advance and cancel
- 100-year non-volatile program memory
- Electronic diagnostic circuit breaker
- Alarm light visible through outer door
- RASTER™ diagnostic test
- 6-pin remote connector
- Removable faceplate programmable under battery power

## Operating Specifications

- Station timing from Central: Programmable in seconds, minutes, and hours; 0 seconds to 12 hours in 1-second increments
- Station timing from Satellite: 0 to 120 minutes selectable in 1-minute increments; above 120 minutes selectable in 10-minute increments
- Automatic starts: 8 start times per program on the quarter hour for up to a total of 32 start times per day using all programs; 24 start times maximum per station
- 4 independent programs (ABCD) with Custom, Odd, Odd31, Even, and Cyclical program day cycles with week days off; D program can overlap ABC programs



## Electrical Specifications

- Input required: 120VAC +/-10%, 60Hz; 230VAC +/-10%, 50Hz; 240VAC +/-10%, 50Hz
- Output: 26.5 VAC, 1.9A
- Surge protection: primary input – MOV; secondary output – MOV, 1 per station
- Power back-up: Lithium coin-cell battery maintains date/time; Non-volatile memory maintains programming
- Multi-station capacity; Up to two 24VAC, 7A solenoid valves per station plus a master valve
- NEMA 3R rated enclosure
- UL, FCC, CUL, CSA, CE, C-Tick, S-Mark Certifications

## Dimensions

- Width: 14.32 in. (36,4 cm)
- Height: 12.69 in. (32,2 cm)
- Depth: 5.50 in. (14,0 cm)

## How to Specify/Order

### LXM - 24 - DTC-PR

| Model                        | Number of Stations        | Direct to Central Communication Interface Cartridge |
|------------------------------|---------------------------|---|
| LXM-DTC Satellite Controller | 8, 12, 16, 20, 24, 28, 32 | PR: Phone+RS232<br>R: RS232 only                    |

### Options

LXMI: Indoor 120V  
 LXM: Outdoor 120V  
 ILXM: Outdoor 230V International  
 ILXMA: Outdoor 240V International

## U-DTC-LXM Upgrade Kit Features

- Upgrade an ESP-LX Modular Controller to an IQ LXM-DTC Satellite Controller
- Modular DTC Communications Interface Cartridge snaps into dedicated bay on back of controller faceplate
- Installs in seconds with no tools required
- Ribbon cable connects DTC-LXM cartridge to the controller
- Status LEDs show current status of communication
- Upgrade Kit includes DTC-LXM cartridge, IQ Satellite Controller faceplate overlay, communication cables, and manual
- Communications options include phone modem or RS-232 port for external modem or direct connect
- DTC-LXM firmware is re-flashable from IQ Central Computer

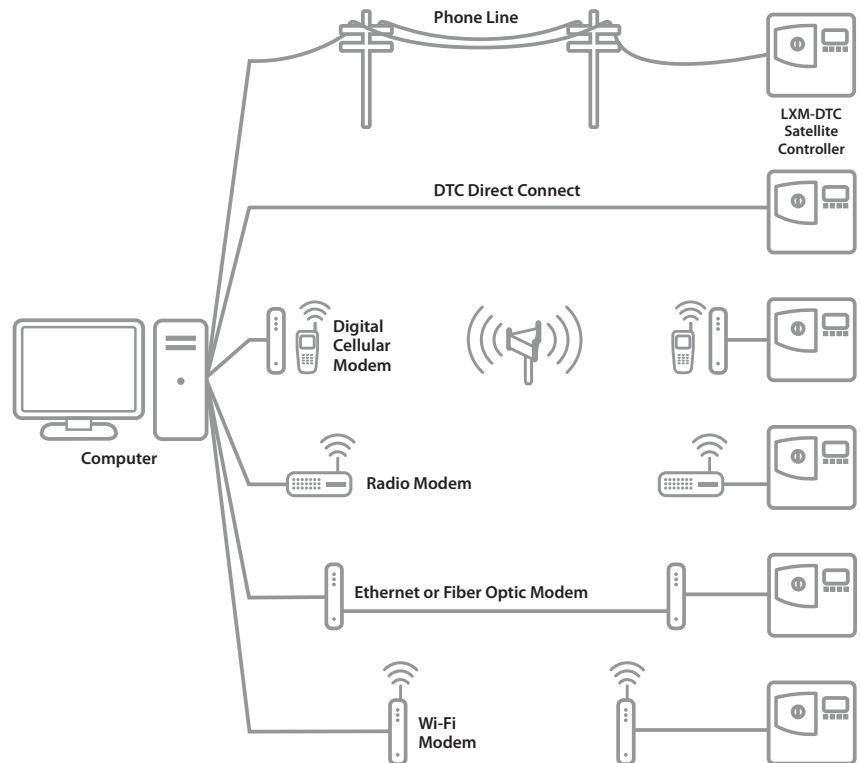

## How to Specify/Order

### U-DTC-LXM - PR

**Model**  
U-DTC-LXM

**Direct to Central Communication Interface Cartridge**  
PR: Phone+RS232  
R: RS232 only

## Communication Options

The IQ software can communicate to the LXM-DTC Satellite Controllers through several options:

- **Phone** – Plain Old Telephone Service (POTS) dial-up phone line
- **Direct Connect** – DTC direct connect cable connection (included with IQ-STD-CD)
- **External Modems** – Contact the Rain Bird Specification Hotline (800) 458-3005 for a list of tested and approved external modems:
  - **Cellular** – digital cellular modems for wireless communication
  - **Radio** – point-to-point radio for short-range, line-of-site communication
  - **Ethernet** – Ethernet device servers for use on a LAN/WAN
  - **Wi-Fi** – Wireless Ethernet device servers for use on a LAN/WAN
  - **Fiber Optics** – Fiber-optic modem on dedicated stands or over an Ethernet network
  - **Short-Haul** – Long-Range wired modem communication devices

## Sensors and Accessories

IQ LXM-DTC Satellite Controllers incorporate a sensor input, programmable by station, for irrigation shut-down in case of weather or flow related event. Rain Bird offers several optional sensors and accessories that are compatible with the IQ Central Control System.

Contact the Rain Bird Specification Hotline (800) 458-3005 for a list of tested and approved sensors and accessories:

- **Weather Sensors** - Rain, wind, or freeze sensors
- **Flow Sensors** - High-flow shut-off sensors
- **Satellite Remote Control** - Radio remote kit (transmitter and receiver)
- **Packaged System Enclosures** - UL Listed, wall-mount or pedestal, pre-assembled enclosures



## Specifications

The automatic sprinkler controls shall be the IQ™ Central Control System as hereinafter specified and as shown on the drawings. The system shall be fully programmable, providing the operator with absolute and full control of the entire control system. The system shall provide a degree of flexibility such as that, in effect, anything that could be done at the satellite controller shall be capable of being done at the central computer.

The system shall have a Windows® graphical user interface (GUI) that allows easy programming and graphical depiction of the central control system programming.

The system shall utilize log-on passwords to administer access privileges to multiple users of the system.

The system shall allow virtual site configurations, allowing the user to group satellite controllers into a site to simplify common adjustments.

The system shall incorporate a program dry-run feature that graphically depicts program operation, showing minute-by-minute system activity and flow rates. The dry-run graph shall also display water window and maximum flow settings.

The system shall incorporate program adjust % values for each program. The system shall also include user-definable monthly seasonal adjust % values that automatically adjust the station run time for each month of the year. The system shall also utilize monthly ET values or user entered daily ET values to adjust station run time.

The system shall be capable of fully integrating with the LXM-DTC Satellite Controller by use of a DTC-LXM Communication Interface Cartridge. This cartridge shall mount inside the controller and incorporate dedicated connectors for controller and central computer communication. The Satellite shall have a dedicated dial position for viewing DTC-LXM information in the controller display.

The LXM-DTC Satellite Controller shall utilize station output modules in 4- or 8-station capacity for a total controller capacity from 8 to 32 stations. These modules shall utilize plug-and-play technology and be hot swappable.

The software system shall incorporate a site configuration utility that contacts the LXM-DTC Satellite Controller and reports the number and slot location of installed controller station output modules for ease of programming.

The system shall allow the LXM-DTC Satellite Controller and DTC-LXM Interface Cartridge firmware to be flashed through the central software. The RASTER™ diagnostic test program shall also be operational through the central software.

The system shall incorporate the capability to override the actual Auto/Off dial and Sensor Active/Bypass switch settings from the central software.

The software system shall utilize two-way communication, not only to send programming data, but also to retrieve logs, alarms and programming change notifications from the controller.

The LXM-DTC Satellite Controller shall incorporate a sensor input for a weather or flow-limit sensor. This sensor shall be utilized to interrupt irrigation if a user-defined condition exists. This sensor interrupt function shall be programmable by station. The master valve/pump start circuit shall also be programmable by station.

The LXM-DTC Satellite Controller shall incorporate an alarm light visible with the controller door in the closed and locked position.

The IQ™ Central Control System shall be as manufactured by Rain Bird Corporation, Glendora, California.

---

### Rain Bird Corporation

6991 E. Southpoint Road, Tucson, AZ, 85706, U.S.A.  
Phone: (520) 741-6100 Fax: (520) 741-6522

### Rain Bird Corporation

970 W. Sierra Madre Avenue, Azusa, CA, 91702, U.S.A.  
Phone: (626) 812-3400 Fax: (626) 812-3411

### Rain Bird International, Inc.

P.O. Box 37, Glendora, CA, 91740-0037, U.S.A.  
Phone: (626) 963-9311 Fax: (626) 852-7343

### Technical Service and Support

(800) RAINBIRD (U.S. and Canada only)

### Specification Hotline

(800) 458-3005 (U.S. and Canada only)

### www.rainbird.com

The Intelligent Use of Water™ -- Visit [www.rainbird.com](http://www.rainbird.com) to learn about our efforts